

AGENDA
Stoneville Town Council Meeting
May 10, 2016
7:00 PM

Call to Order-Mayor Craddock
Pledge of Allegiance
Invocation
Approval of Minutes from Last Meetings
Approval of Agenda

New Business:

1. Stoneville Police Department Promotional Ceremony – Chief Moore
2. NCDOT Downtown Sidewalk Improvements – Jason Julian
3. Rockingham County Crime Stoppers Funding Request – Anne Wade
4. 2016 Bark for Life Event – Chrissy Griffin
5. Asset Inventory & Assessment Grant – Ken Gamble
 - a. Resolution by Governing Body of Applicant for AIA Grant – Sewer System
 - b. Resolution by Governing Body of Applicant for AIA Grant – Water System
6. Budget Amendment – Joanna Dalton
7. Proclamation National Police Week 2016 – Ken Gamble
8. Proclamation Public Works Week 2016 – Ken Gamble
9. Change of Date for June 2016 Council Meeting – Mayor Craddock

Public Comments:

Old Business:

1. Weapons on Town Owned Property – Ken Gamble

Town Manager Report:

1. Bulky Item Pick-Up Week Report
2. Inquiry Regarding Service Logistics Tank on Mebane Street
3. Matthews Street Project Update
4. Pack the Park
5. Cruise In – Friday May 20th 5p-8p
6. Public Budget Meeting – Thursday May 26th 6:00 p.m.

Executive Session Into:

Executive Session Out Of:

Adjourn/Recess:

**Stoneville Town Council
Special Meeting Minutes
April 5, 2016
6:00 PM**

Present: Present were Mayor Ricky Craddock, Councilwoman Lori Armstrong, Councilmen Bill Farris, Henry Thornton and Jerry Smith. Mayor Pro-Tem Chuck Hundley was excused.

Also present were Town Manager Kenneth Gamble, Human Resource/Finance Officer Joanna Dalton, Town Clerk Sherri Darnell, Public Works Director Mark Malloy, and Town Attorney Travis Martin.

Welcome: Mayor Ricky Craddock called the meeting to order.

Town Manager Gamble stated that NC House Representative Kyle Hall had called stating he could not make this meeting. However, Mr. Gamble presented information gathered from the NC League of Municipalities website about priorities for the 2016 NC Legislature short session. If Council has any questions or concerns Mr. Gamble will refer them to Representative Hall. Copy incorporated into the minutes.

After some discussion, Mr. Gamble was directed to present several questions and concerns to Representative Hall.

Adjourn: Mayor Craddock asked for a motion for adjournment. Councilman Smith made a motion to adjourn the meeting. Councilman Thornton seconded the motion. Motion carried.

Mayor Ricky Craddock

Town Clerk Sherri Darnell

**Stoneville Town Council
Regular Meeting Minutes
April 5, 2016
7:00 PM**

Present: Present were Mayor Ricky Craddock, Councilwoman Lori Armstrong, Councilmen Bill Farris, Henry Thornton and Jerry Smith. Mayor Pro-tem Chuck Hundley was excused.

Also present were Town Manager Kenneth Gamble, Human Resource/Finance Officer Joanna Dalton, Town Clerk Sherri Darnell, Public Works Director Mark Malloy, Police Chief Frank Moore, Police Officer Brandon Rivera, Police Officer Josh Cayton, Police Administrative Assistant Perry Webster, Parks & Recreation Director Jackie Blackard and Town Attorney Travis Martin.

Welcome: Mayor Ricky Craddock welcomed the assembly. After the Pledge of Allegiance and Invocation, Mayor Craddock called the meeting to order.

Minutes: Mayor Ricky Craddock asked if there were any corrections to the minutes from the last meeting. With one correction to Page 2, see notation in italics in the March minutes, Mayor Craddock asked for a motion to approve the minutes with this correction. Councilman Farris made the motion to approve the minutes. Councilman Thornton seconded the motion. Motion carried.

Agenda: Mayor Ricky Craddock asked if there were any adjustments to the originally submitted Agenda. Town Manager Gamble asked to add as #8 Proclamation of Municipal Clerks Week. With that change Mayor Craddock asked for a motion to approve the Agenda. Councilwoman Armstrong made the motion to approve the Agenda. Councilman Smith seconded the motion. Motion carried.

New Business:

Students Against Destructive Decisions: Ms. Parker Hundley approached Council regarding the annual breakfast that is held at Dalton L. McMichael High School after the Prom. Ms. Hundley stated that they hold this breakfast event to try to help students make smarter and safer choices regarding the Prom and their activities afterwards. Ms. Hundley stated that this year they are soliciting municipalities to help with some of the costs associated with this event (food, decorations, t-shirts, etc.) by contributing \$500.00 (five hundred dollars). By consensus, Council decided to table this discussion until the budget meeting being held April 11, 2016. After this meeting, the S. A. D. D. chapter would be notified of the decision.

Storm Water Pipe Replacement: Town Manager Gamble stated that the storm drain located in the 100 block of Woodland Avenue is in need of replacement. Mr. Gamble stated that the initial complaint was received in September, but was on the property owner's owner's side. The next complaint was reported as a sink hole on Woodland Avenue. Mr. Gamble and Town Engineer Bill Lester investigated and noted that the entire drain pipe running underneath the roadway was rusted away at the bottom. Mr. Gamble stated that he and Engineer Lester believe this problem can be repaired in the 2016-2017 budget year. Copy incorporated into the minutes.

- Personnel Ordinance Revision: Finance/HR Officer Dalton presented Personnel policy revisions to the Council stating that the changes were in response to our adoption of the Manager-Council form of government. Councilman Smith made a motion to revise the Personnel policy ordinance as proposed in the documentation. Councilman Farris seconded the motion. Motion carried. Copy incorporated into the minutes.
- Revision To Cruise-In Ordinance: Town Manager Gamble advised the Council that this revision was being made to reflect the change in the Cruise in dates, April through September rather than May through October. Councilwoman Armstrong made the motion to adopt the revision to the ordinance. Councilman Thornton seconded. Motion carried. Copy incorporated into the minutes.
- Weapons On Town Owned Property: Town Manager Gamble advised Council that a question had been asked about weapons being carried concealed or otherwise on town property. After some discussion, this issue was tabled until the May meeting.
- Transfer Of Stoneville Football & Cheer Programs: Town Manager Gamble stated that Parks & Rec. Director Blackard has been talking to the western Rockingham football providers that feed McMichael High School. These programs along with McMichael High School have organized the Jr. Phoenix Football Program. This program will also include cheerleading. Blackard and Town Manager Gamble recommended that the Town transfer our football and cheerleading programs from our Parks and Recreation Department to the Jr. Phoenix program. After some discussion Councilman Smith made the motion to allow the transfer. Councilman Thornton seconded the motion. Motion carried. Copy incorporated into the minutes.
- Asset Inventory & Assessment Grant: Town Manager Gamble asked for permission to apply for the Asset Inventory and Assessment Grant. The grant would provide for a full inventory and assessment of the Town's water and sewer infrastructure and equipment. It would lay the ground work for an Operations & Maintenance manual and new Capital Improvement Plan. Mr. Gamble stated that this grant, if awarded, would be an asset to the management of the department and town. The grant is due April 29 and Mr. Gamble will not have the grant matching amount until the May 10 Council meeting. Councilman Farris made the motion to allow the application. Councilman Thornton seconded the motion. Motion carried.
- Municipal Clerks Week: Mayor Craddock read the Proclamation of Municipal Clerks Week, May 1st through the 7th. Mayor Craddock then asked for a motion to accept this proclamation. Councilman Smith made the motion to accept this proclamation. Councilwoman Armstrong seconded the motion. Motion carried. Copy incorporated into the minutes.
- Public Comments: Mr. Eugene DeMoss of 200 Forrest Street spoke for his right to carry a firearm and protect himself and anyone else who may need it.

Mr. Al Robbins informed Council that the website was now stable and the pdf files are being added by Mrs. Darnell, she is doing a good job and that the website will be good through 2019. Mr. Robbins then stated that the citizens should be notified of things that are going to be discussed in the meetings so that they would be prepared to speak during Public Comments.

Old Business:

Erosion In 200 Block of Forrest St: Public Works Director Malloy explained to Council about the erosion to a ditch at the dead end of Forrest Street. Director Malloy described how the recent heavy rains that we have experienced had made the ditch a hazard. In order to correct this problem, Director Malloy corrected pipe settling and covered the eroded area with rip-rap to better channel storm water runoff. Director Malloy stated that this area will be monitored for any further problems.

Town Manager Report:

Town Manager Gamble stated that the Public Budget Meeting will be held on Monday, April 11th at 6 PM.
Bulk Item pick up week is April 11th – 15th.
The ribbon cutting and inaugural walk for the Downtown connector trail will be Sunday, April 17th from 2 until 4 PM starting at the park and with light refreshments to be served at the Celebration Events Center for the walkers.
Stoneville High School Reunion for students, staff and their families will be at the Gymnasium on Saturday, April 30th from 4-7 PM.
Matthews Street project has broken ground with roughly 500 feet of replacement sewer line laid thus far.
Pack the Park is May 14, 2016, primary fundraiser for Parks & Recreation.
Thanks to Perry Webster for working on the Canon Grant for \$32,000 for Fire Department radios and pagers.
Town Manager Gamble then recognized Chief Moore and Moore updated the Council on the training that our officers are receiving.

Chief Moore presented Officer Josh Cayton his certifications for DCI, CJLEADS, NC Aware, ARIDE, SFST, INTOX and RADAR. Everyone in attendance gave Officer Cayton a big round of applause.

NC House Representative Kyle Hall introduced himself to the Council and apologized for being unable to meet with them before the regular Council meeting. He asked that they contact him with any questions or concerns.

Executive Session: Mayor Craddock asked for a motion to enter into executive session. Councilman Farris made the motion. Councilman Thornton seconded. Motion carried.

Regular Session: Mayor Craddock asked for a motion to return to regular session. Councilman Farris made the motion. Councilwoman Armstrong seconded. Motion carried.

Mayor Craddock stated that during Executive Session a personnel issue and a property matter were discussed with no action taken.

Adjourn: Mayor Craddock asked for a motion for adjournment. Councilman Smith made a motion to adjourn the meeting. Councilwoman Armstrong seconded the motion. Motion carried.

Mayor Ricky Craddock

Town Clerk Sherri Darnell

**Stoneville Town Council
Public Budget Meeting
Minutes April 11, 2016
6:00 PM**

Present: Present were Mayor Ricky Craddock, Mayor Pro-Tem Chuck Hundley, Councilwoman Lori Armstrong, Councilmen Bill Farris, Henry Thornton and Jerry Smith.

Also present were Town Manager Kenneth Gamble, Human Resource/Finance Officer Joanna Dalton, Town Clerk Sherri Darnell, Public Works Director Mark Malloy, Fire Chief Tim Brown, Police Officer Brandon Rivera, and Police Administrative Assistant Perry Webster

Welcome: After the Pledge of Allegiance and Invocation, Mayor Ricky Craddock called the meeting to order.

Agenda: Mayor Craddock asked for approval of the Agenda. Town Manager Gamble asked to have one additional item added, Public Comments. With this addition, Mayor Craddock asked for a motion to approve the Agenda with this addition. Councilwoman Armstrong made the motion with Councilman Farris seconding. Motion carried.

Budget Presentation: Town Manager Gamble gave a Power Point presentation of the budget for the 2016/2017 Budget year. Copy incorporated into the minutes.

Police Dept. Request For Additional Funding: Police Administrative Assistant Webster described how much comp time is accumulated because of training, court appearances, etc., and how by raising the Part Time salary to \$13.50 per hour, could attract better qualified candidates as well as allow our officers the ability to take the time off that has been accumulated without affecting the entire department. Mr. Webster also stated that the Police Department is requesting the approval to apply to the USDA for another vehicle. The grant could be up to 55% and allow a payment of \$1,800.00 monthly. (Copy incorporated into the minutes) Town Manager Gamble stated that the initial budget request was \$40,000.00 and \$7,500 had been cut.

Public Comments: Mr. Maurice Raynor of 217 Carlea Lane spoke regarding salaried vs. hourly employees and if they would be losing any benefits due to the FLSA law that would be effective July 1, 2016. Town Manager Gamble explained to Mr. Raynor that no benefits would be lost due to this new rule.

Mr. Johnny Farmer of 104 Pine Cone Drive asked about the availability of the Budget documents. Mr. Farmer was advised that these documents will be available on May 27th after the May 26th Public Budget Meeting. Mr. Farmer asked if the Parks & Recreation budget will be cut with football and cheerleading going over to the Jr. Phoenix program? Town Manager Gamble stated that another fall sport will be added and determination of the budget amount will be decided then. Mr. Farmer asked if the Insurance for the town employees is bid out every year. Finance Officer Dalton explained that we

send out requests every year for our Insurance to find comparable benefits at a lesser rate. Mr. Farmer also asked regarding the request for a part-time fireman. Chief Brown stated that we need someone available that is a certified driver to check on scene. Mr. Farmer asked about the Police Department vehicle purchase. Administrative Assistant Webster explained that the 1998 Crown Victoria is the only spare that the department has and is really not safe to drive.

Mr. Steve Ruminek of 212 Forrest Street stated that he did not support adding the \$5.00 per registered vehicle tax. Mr. Ruminek then asked regarding the part-time position on the Fire Department. Town Manager Gamble stated that this position would be rotated between 3 or 4 people. Mr. Ruminek asked about the amount of the telephone request by the Police Department for the Officer on duty to use, rather than using their personal phones. Mr. Gamble stated that in order for it to be on our government contract, we had to go with Verizon.

Old Business:

S.A.D.D. Request: Town Manager Gamble stated that the McMichael SADD chapter has requested \$500.00 to be used for their Prom breakfast. Council wanted to discuss this at this meeting. Councilman Thornton made a challenge to all council members to donate \$50.00 each and try to find another local organization to make up the difference. Each councilmember agreed.

After much discussion and by consensus, the Council instructed Town Manager Gamble to look at increasing the property tax rate, look through more line items and see if adjustments can be made to include Chief Moore's request to restore full funding to part-time salaries.

Adjourn: Mayor Craddock asked for a motion for adjournment. Mayor Pro-tem Hundley made a motion to adjourn the meeting. Councilman Farris seconded the motion. Motion carried.

Mayor Ricky Craddock

Town Clerk Sherri Darnell

See Sheet 1-A For Index of Sheets

VICINITY MAP

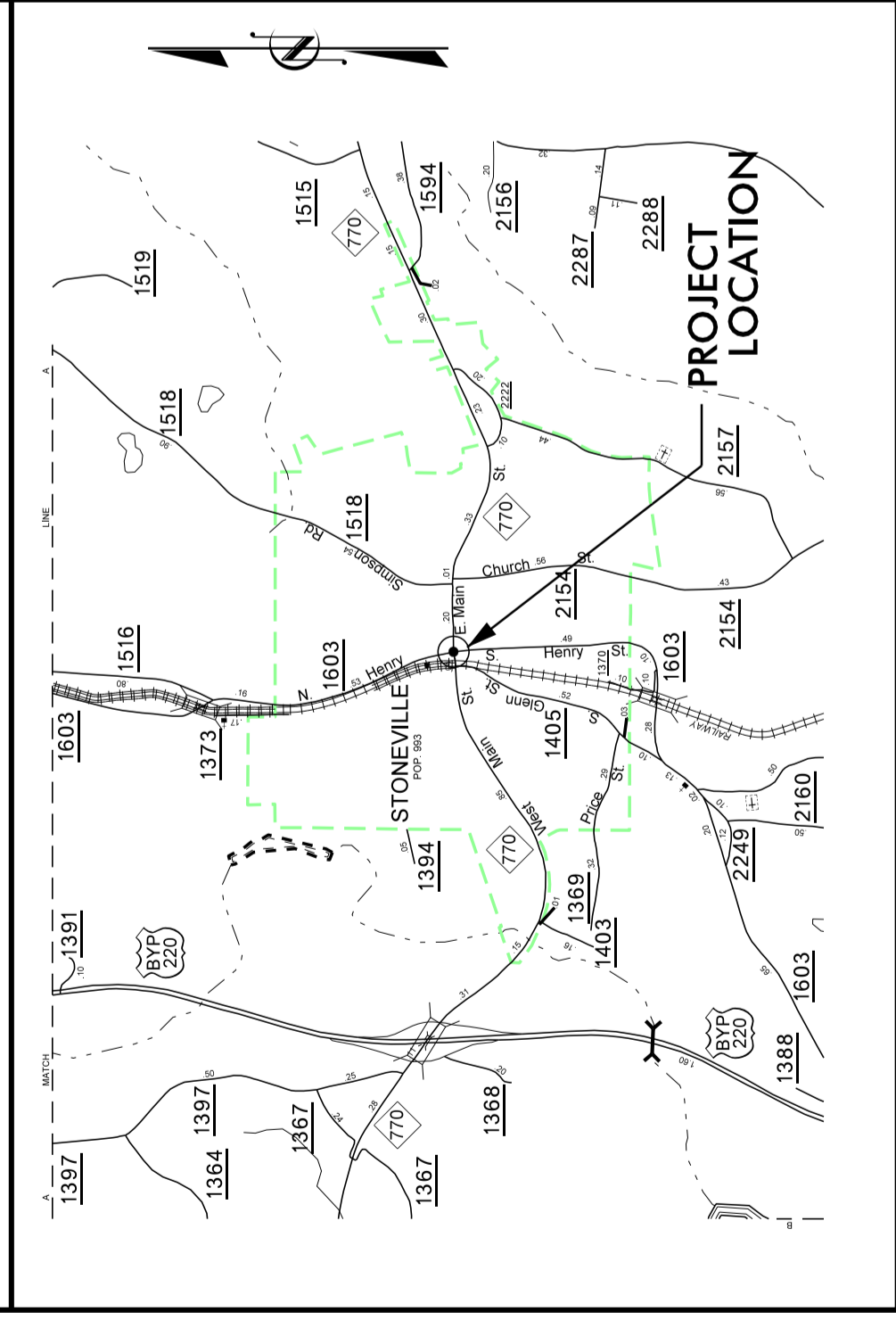

STATE OF NORTH CAROLINA
DIVISION OF HIGHWAYS

ROCKINGHAM

LOCATION: NORTHEAST & NORTHWEST CORNERS OF NC 770 & SR 1603 (HENRY ST)

TYPE OF WORK: REPLACE AND MODIFY EXISTING SIDEWALK, INSTALL CURB RAMPS AND CROSSWALKS

TIP PROJECT: 44473

CONTRACT:

GRAPHIC SCALES

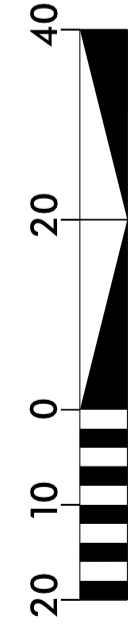

PLANS

DESIGN DATA

ADT 2014 = 4900
(NC 770 - E MAIN ST.)

FUNC CLASS =
NC 770 (W. MAIN ST.) - MAJOR COLLECTOR
NC 770 (E. MAIN ST.) - MINOR ARTERIAL
SR 1603 (HENRY ST.) - MINOR ARTERIAL

PROJECT LENGTH

SIDEWALK MODIFICATIONS & REPLACEMENTS
NO PROJECT LENGTH APPLICABLE

Prepared in the Office of:

DIVISION OF HIGHWAYS

1584 YANCEYVILLE STREET, GREENSBORO, NC 27405

2012 STANDARD SPECIFICATIONS

RIGHT OF WAY DATE:

C.B. SMITHERMAN, P.E.
PROJECT ENGINEER

LETTING DATE:

J.A. SOUR
PROJECT DESIGN TECHNICIAN

HYDRAULICS ENGINEER

SIGNATURE: _____ P.E.

ROADWAY DESIGN ENGINEER

SIGNATURE: _____ P.E.

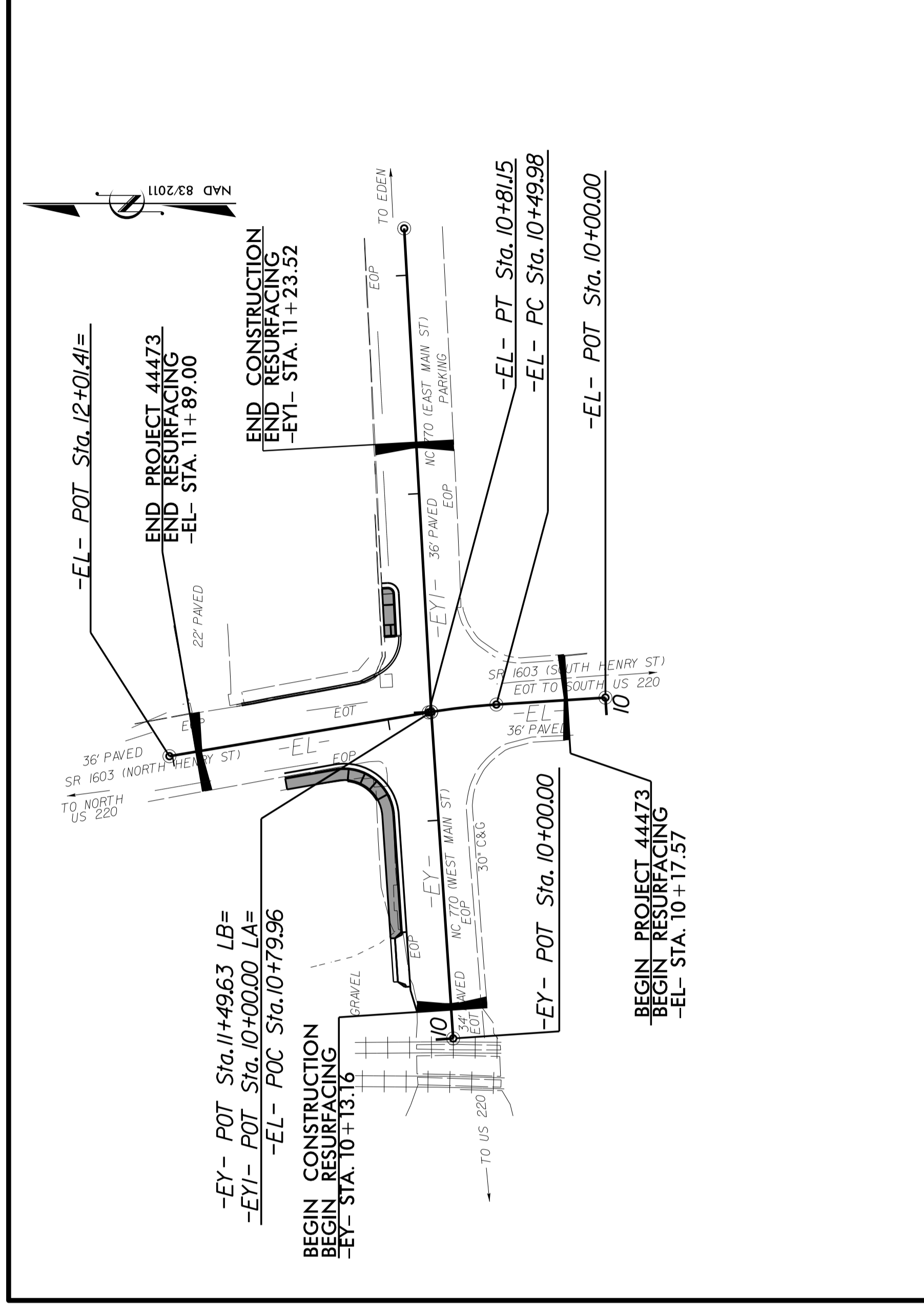

STATE	N.C.	STATE PROJECT REFERENCE NO.	44473	SHEET NO.	1	TOTAL SHEETS	
STATE PROJ. NO.	44473	F.A. PROJ. NO.		DESCRIPTION	P.E.		
	44473				R.W.		
	44473				UTILITIES		
	44473				CONSTRUCTION		

INCOMPLETE PLANS
DO NOT USE FOR R/W ACQUISITION
DOCUMENT NOT CONSIDERED FINAL
UNLESS ALL SIGNATURES COMPLETED

INDEX OF SHEETS

SHEET NUMBER	SHEET
1	TITLE SHEET
1-A	INDEX OF SHEETS, GENERAL NOTES, AND LIST OF STANDARD DRAWINGS
1-B	CONVENTIONAL SYMBOLS
2 - 2B	PAVEMENT SCHEDULE, TYPICAL SECTION, CURB RAMPS, SURVEY DATA SHEET
4	PLAN SHEET
PMP1	PAVEMENT MARKING PLAN
EC-1	EROSION CONTROL PLAN
X-1 THRU X-4	CROSS SECTIONS

2012 ROADWAY STANDARD DRAWINGS

EFF. 01-17-12

The following Roadway Standards as appear in "Roadway Standard Drawings" Highway Design Branch - N. C. Department of Transportation - Raleigh, N. C., Dated January 2012, are applicable to this project and by reference hereby are considered a part of these plans:

STD.NO.	TITLE
DIVISION 2 - EARTHWORK 225.02	Guide for Grading Subgrade - Secondary and Local
DIVISION 3 - PIPE CULVERTS 300.01	Method of Pipe Installation
DIVISION 6 - ASPHALT BASES AND PAVEMENTS 654.01	Pavement Repairs
DIVISION 8 - INCIDENTALS 840.00	Concrete Base Pads for Drainage Structures
840.25	Anchorage for Frames
840.35	Traffic Bearing Grated Drop inlet - for Cast Iron Double Frame and Grates
840.36	Traffic Bearing Grated Drop inlet - for Steel (840.37) Double Frame and Grates
840.37	Steel Grate and Frame
840.66	Drainage Structure Steps
848.01	Concrete Sidewalk
848.05	Curb Ramp - Proposed Curb and Gutter
DIVISION 11 - WORK ZONE TRAFFIC CONTROL 1101.01	Work Zone Warning Signs
1101.02	Temporary Lane Closures
1101.04	Temporary Shoulder Closures
1101.11	Traffic Control Design Tables
1110.01	Stationary Work Zone Signs
1110.02	Portable Work Zone Signs
1115.01	Flashing Arrow Boards
1130.01	Drums
1135.01	Cones
1150.01	Flagging Devices
1165.01	Work Vehicle Lighting Systems and TMA Delineation
1180.01	Skinny Drum
DIVISION 12 - PAVEMENT MARKINGS, MARKERS AND DELINEATION SEE PMP-1	

GENERAL NOTES

2012 SPECIFICATIONS: EFFECTIVE: 01-17-12 REVISED: 07-30-2012

GRADING AND SURFACING OR RESURFACING AND WIDENING:
THE GRADE LINES SHOWN DENOTE THE FINISHED ELEVATION OF THE PROPOSED SURFACING AT GRADE POINTS SHOWN ON THE TYPICAL SECTIONS. WHERE NO GRADE LINES ARE SHOWN, THE PROFILES SHOWN DENOTE THE TOP ELEVATION OF THE EXISTING PAVEMENT ALONG THE CENTER LINE OF SURVEY ON WHICH THE PROPOSED RESURFACING WILL BE PLACED. GRADE LINES MAY BE ADJUSTED BY THE ENGINEER IN ORDER TO SECURE A PROPER TIE-IN.

CLEARING:

SUPERELEVATION:

MAINTAIN EXISTING SUPERELEVATION.

SHOULDER CONSTRUCTION:

SIDE ROADS:

THE CONTRACTOR WILL BE REQUIRED TO DO ALL NECESSARY WORK TO PROVIDE SUITABLE CONNECTIONS WITH ALL ROADS, STREETS AND DRIVES ENTERING THIS PROJECT. THIS WORK WILL BE PAID FOR AT THE CONTRACT UNIT PRICE FOR THE PARTICULAR ITEMS INVOLVED.

SUBSURFACE PLANS:

NO SUBSURFACE PLANS ARE AVAILABLE ON THIS PROJECT. THE CONTRACTOR SHOULD MAKE HIS OWN INVESTIGATION AS TO THE SUBSURFACE CONDITIONS.

UTILITIES:

UTILITY OWNERS ON THIS PROJECT ARE:

ANY RELOCATION OF EXISTING UTILITIES WILL BE ACCOMPLISHED BY OTHERS.

RIGHT-OF-WAY MARKERS:

ALL RIGHT -OF-WAY MARKERS ON THIS PROJECT SHALL BE PLACED BY OTHERS.

Note: Not to Scale

*S.U.E. = Subsurface Utility Engineering

STATE OF NORTH CAROLINA
DIVISION OF HIGHWAYS

CONVENTIONAL PLAN SHEET SYMBOLS

BOUNDARIES AND PROPERTY:

- State Line
- County Line
- Township Line
- City Line
- Reservation Line
- Property Line
- Existing Iron Pin
- Property Corner
- Property Monument
- Parcel/Sequence Number
- Existing Fence Line
- Proposed Woven Wire Fence
- Proposed Chain Link Fence
- Proposed Barbed Wire Fence
- Existing Wetland Boundary
- Proposed Wetland Boundary
- Existing Endangered Animal Boundary
- Existing Endangered Plant Boundary

BUILDINGS AND OTHER CULTURE:

- Gas Pump
- Sign
- Well
- Small Mine
- Foundation
- Area Outline
- Cemetery
- Building
- School
- Church
- Dam

HYDROLOGY:

- Stream or Body of Water
- Hydro, Pool or Reservoir
- Jurisdictional Stream
- Buffer Zone 1
- Buffer Zone 2
- Flow Arrow
- Disappearing Stream
- Spring
- Wetland
- Proposed Lateral, Tail, Head Ditch
- False Sump

RAILROADS:

- Standard Gauge
- RR Signal Milepost
- Switch
- RR Abandoned
- RR Dismantled

RIGHT OF WAY:

- Baseline Control Point
- Existing Right of Way Marker
- Existing Right of Way Line
- Proposed Right of Way Line
- Proposed Right of Way Line with Iron Pin and Cap Marker
- Proposed Right of Way Line with Concrete or Granite Marker
- Existing Control of Access
- Proposed Control of Access
- Existing Easement Line
- Proposed Temporary Construction Easement
- Proposed Temporary Drainage Easement
- Proposed Permanent Drainage Easement
- Proposed Permanent Drainage / Utility Easement
- Proposed Permanent Utility Easement
- Proposed Temporary Utility Easement
- Proposed Permanent Easement with Iron Pin and Cap Marker

ROADS AND RELATED FEATURES:

- Existing Edge of Pavement
- Existing Curb
- Proposed Slope Stakes Cut
- Proposed Slope Stakes Fill
- Proposed Wheel Chair Ramp
- Existing Metal Guardrail
- Proposed Guardrail
- Existing Cable Guiderail
- Proposed Cable Guiderail
- Equality Symbol
- Pavement Removal

VEGETATION:

- Single Tree
- Single Shrub
- Hedge
- Woods Line
- Orchard
- Vineyard

EXISTING STRUCTURES:

- MAJOR:
 - Bridge, Tunnel or Box Culvert
 - Bridge Wing Wall, Head Wall and End Wall
- MINOR:
 - Head and End Wall
 - Pipe Culvert
 - Footbridge
 - Drainage Box: Catch Basin, DI or JB
 - Paved Ditch Gutter
 - Storm Sewer Manhole
 - Storm Sewer

UTILITIES:

- POWER:
 - Existing Power Pole
 - Proposed Power Pole
 - Existing Joint Use Pole
 - Proposed Joint Use Pole
 - Power Manhole
 - Power Line Tower
 - Power Transformer
 - UG Power Cable Hand Hole
 - H-Frame Pole
 - Recorded UG Power Line
 - Designated UG Power Line (S.U.E.*)
- TELEPHONE:
 - Existing Telephone Pole
 - Proposed Telephone Pole
 - Telephone Manhole
 - Telephone Booth
 - Telephone Pedestal
 - Telephone Cell Tower
 - UG Telephone Cable Hand Hole
 - Recorded UG Telephone Cable
 - Designated UG Telephone Cable (S.U.E.*)
 - Recorded UG Telephone Conduit
 - Designated UG Telephone Conduit (S.U.E.*)
 - Recorded UG Fiber Optics Cable
 - Designated UG Fiber Optics Cable (S.U.E.*)

WATER:

- Water Manhole
- Water Meter
- Water Valve
- Water Hydrant
- Recorded UG Water Line
- Designated UG Water Line (S.U.E.*)
- Above Ground Water Line

TV:

- TV Satellite Dish
- TV Pedestal
- TV Tower
- UG TV Cable Hand Hole
- Recorded UG TV Cable
- Designated UG TV Cable (S.U.E.*)
- Recorded UG Fiber Optic Cable
- Designated UG Fiber Optic Cable (S.U.E.*)

GAS:

- Gas Valve
- Gas Meter
- Recorded UG Gas Line
- Designated UG Gas Line (S.U.E.*)
- Above Ground Gas Line

SANITARY SEWER:

- Sanitary Sewer Manhole
- Sanitary Sewer Cleanout
- UG Sanitary Sewer Line
- Above Ground Sanitary Sewer
- Recorded SS Forced Main Line
- Designated SS Forced Main Line (S.U.E.*)

MISCELLANEOUS:

- Utility Pole
- Utility Pole with Base
- Utility Located Object
- Utility Traffic Signal Box
- Utility Unknown UG Line
- UG Tank; Water, Gas, Oil
- AG Tank; Water, Gas, Oil
- UG Test Hole (S.U.E.*)
- Abandoned According to Utility Records
- End of Information

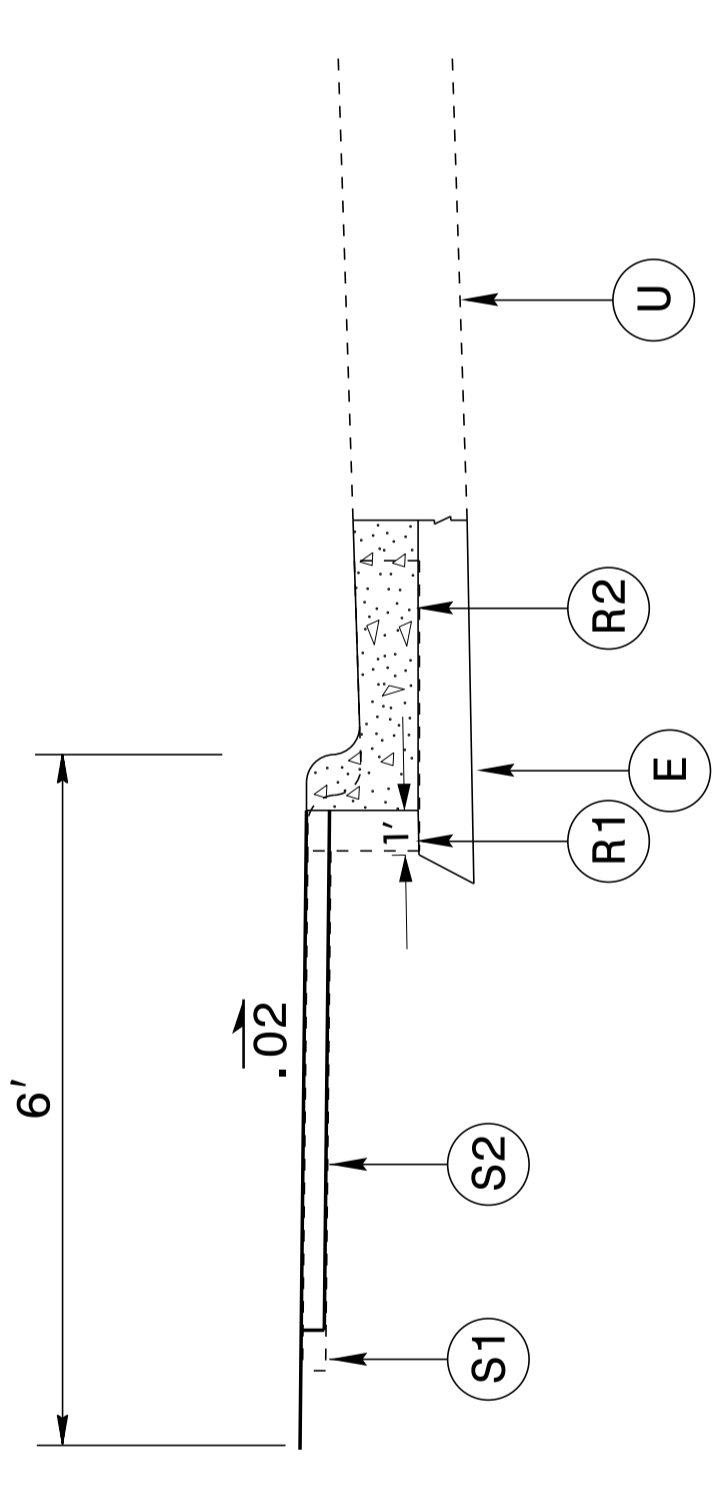

TYPICAL SECTION 1 (N/S)

- EL- STA. 11+10.00 (LT) TO -EL- STA. 11+50.90 (LT)
- EY- STA. 10+47.62 (LT) TO -EY- STA. 11+20.00 (LT)

STEP DETAIL

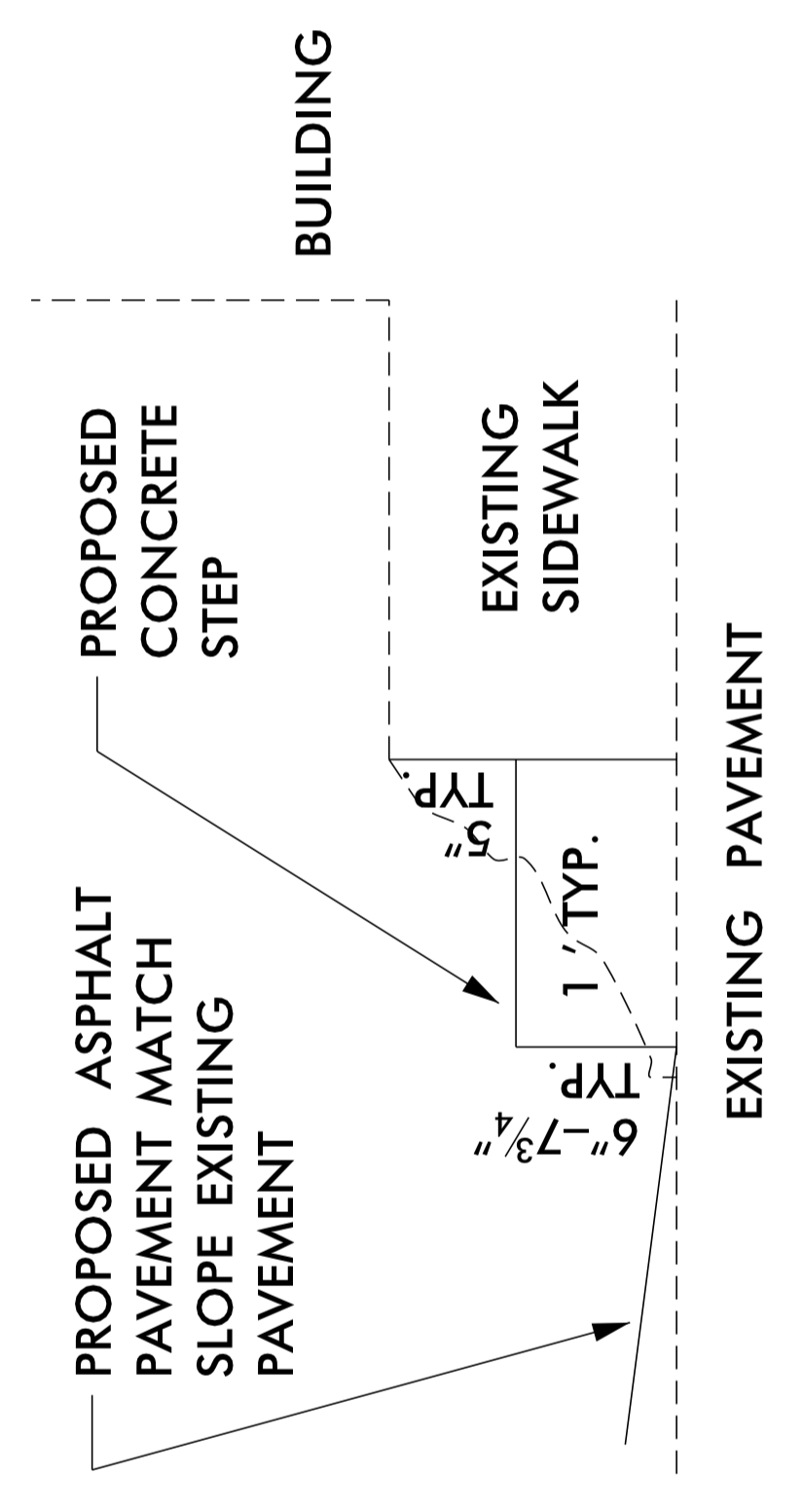

MEASUREMENTS TO START FROM THE TOP OF SIDEWALK. EXISTING CURB TO BE REMOVED FROM SIDEWALK. A CLEAN JOINT MUST BE MADE AT THE FACE OF THE SIDE WALK.

- EL- STA. 11+02.50 (RT) TO -EL- STA. 11+60.00 (RT)
- EY1- STA. 10+17.97 (LT) TO -EY1- STA. 10+35.82 (LT)

E	PROP. APPROX. 3" ASPHALT CONCRETE BASE COURSE, TYPE B25.0, AT AN AVERAGE RATE OF 342 LBS. PER SQ. YD.
R1	EXISTING 2' - 6" CONCRETE CURB & GUTTER TO BE REMOVED
R2	PROPOSED 2' - 6" CONCRETE CURB & GUTTER
S1	EXISTING 4" CONCRETE SIDEWALK TO BE REMOVED
S2	PROPOSED 4" CONCRETE SIDEWALK
S3	EXISTING 4" CONCRETE SIDEWALK
U	EXISTING PAVEMENT

SURVEY DATA SHEET

-EL- CUR1
 PI Sta 10+65.58
 $\Delta = 5^\circ 57' 08.9''$ (LT)
 D = 19° 05' 54.9"
 L = 31.17'
 T = 15.60'
 R = 300.00'

-EY- POT Sta. 11+49.63 LB=
 -EYI- POT Sta. 10+00.00 LA=
 -EL- POC Sta. 10+79.96

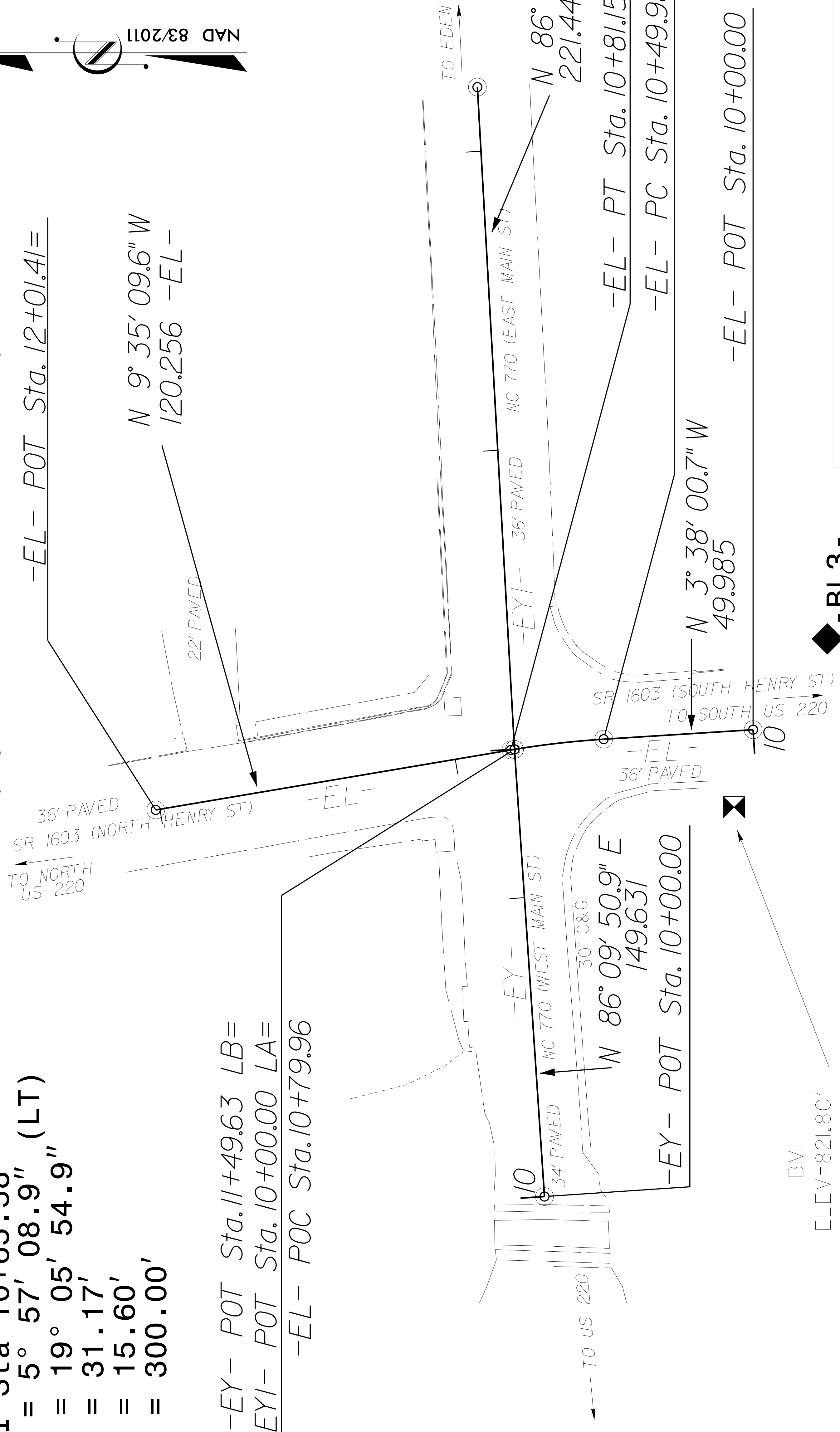

DATUM DESCRIPTION
 THE LOCALIZED COORDINATE SYSTEM DEVELOPED FOR THIS PROJECT IS BASED ON THE STATE PLANE COORDINATES ESTABLISHED BY NCDOT FOR MONUMENT "44473-1" WITH NAD 83/NA 2011 STATE PLANE GRID COORDINATES OF NORTHING: 990580.7180(ft) EASTING: 1733098.9480(ft) ELEVATION: 819.60(ft)
 THE AVERAGE COMBINED GRID FACTOR USED ON THIS PROJECT (GROUND TO GRID) IS: 1.0000641511
 ALL LINEAR DIMENSIONS ARE LOCALIZED HORIZONTAL DISTANCES VERTICAL DATUM USED IS NAVD 88

POINT	NORTH	EAST	ELEVATION	EL STATION	OFFSET
44473-2	991436.3100	1732540.8140	827.04	OUTSIDE PROJECT LIMITS	
44473-1	990580.7180	1733098.9480	819.60	OUTSIDE PROJECT LIMITS	
BL-3 (PK)	989807.9185	1733282.0448	820.70	OUTSIDE PROJECT LIMITS	

BMI
 ELEV=821.80'
 N 989839 E 1733226
 BL STATION 22+72.00 47' RIGHT
 CARVED X ON CORNER OF CURB IN SOUTHERN FINISHING PARKING LOT NEXT TO HENRY ST ENTRANCE.

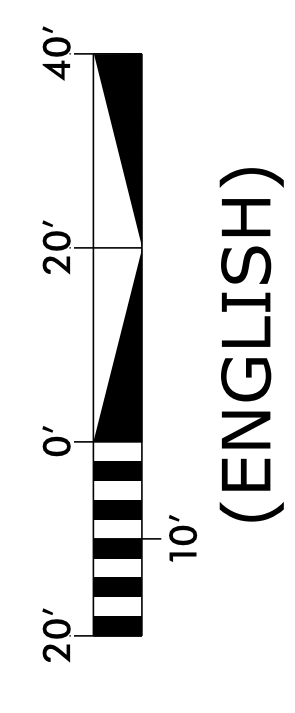

PAY LIMITS FOR 1 CURB RAMP

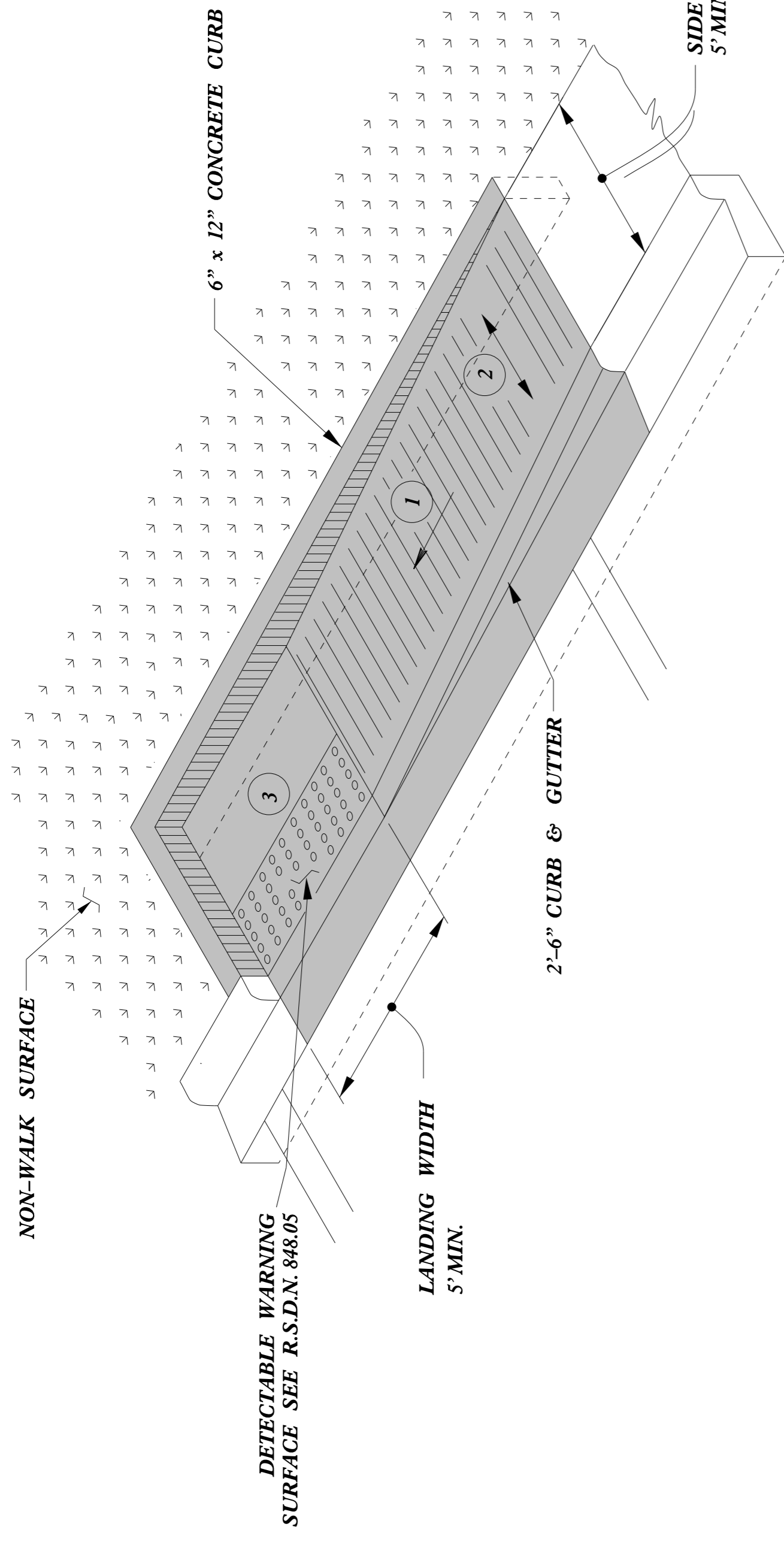

TYPE 1A

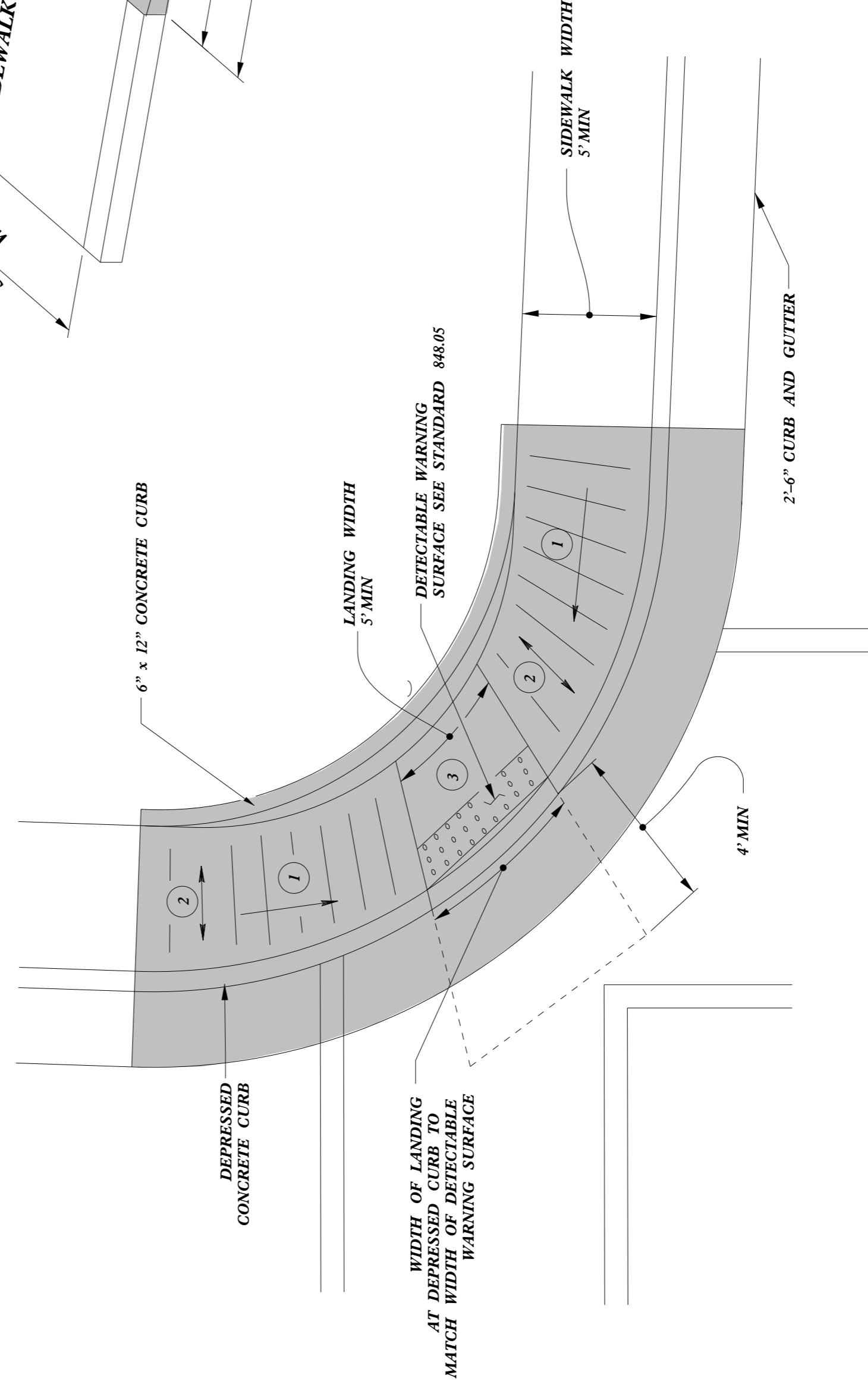

TYPE 2A

- 1 8.33% (12:1) MAX RAMP SLOPE
- 2 CROSS SLOPE: 2.00%
- 3 CURB RAMPS REQUIRE A (4'-0") MINIMUM LANDING WITH A MAXIMUM CROSS SLOPE AND LONGITUDINAL SLOPE OF 2.00% WHERE PEDESTRIANS PERFORM TURNING MANEUVERS. SLOPE TO DRAIN TO CURB.

**DRIVEWAY APRON
OPTION 2**

-SEE ROADWAY DETAIL DRAWING 848.05 2 OF 2 FOR DETECTABLE WARNING SURFACE.
-SEE ROADWAY STANDARD DRAWING 848.02 FOR CONCRETE DRIVEWAYS.

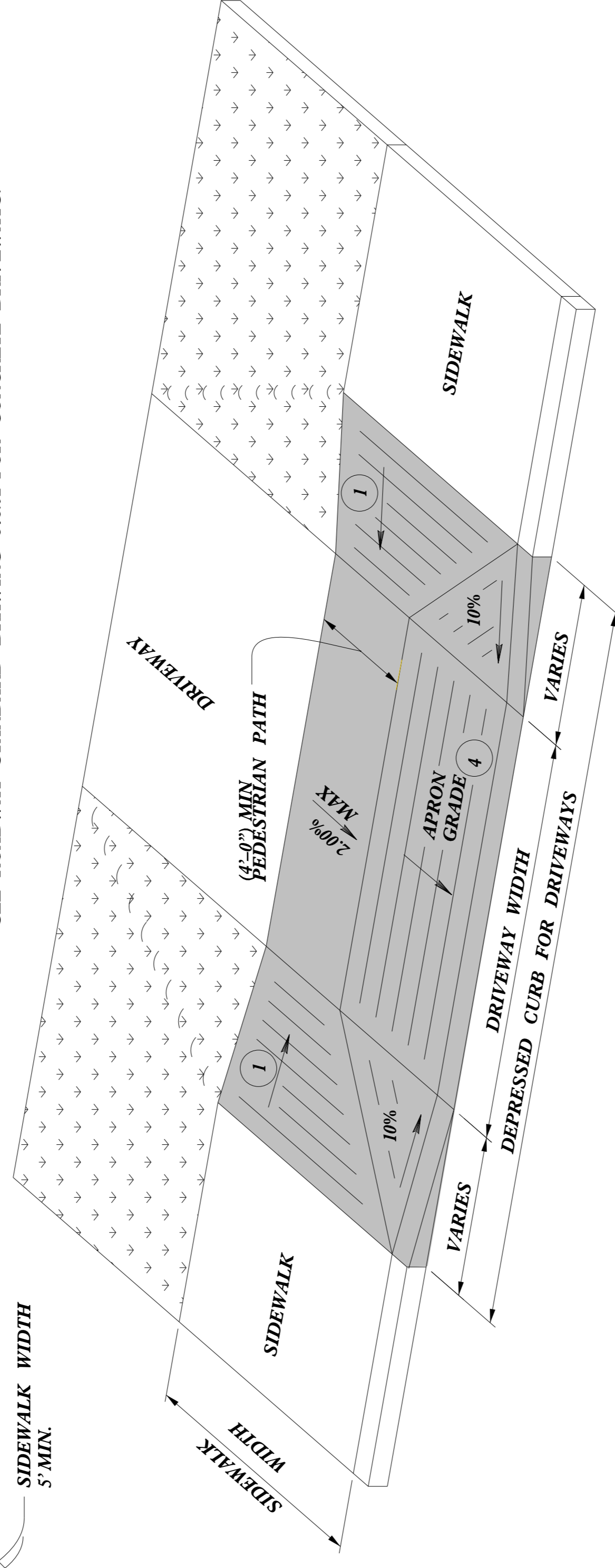

**CONTRACT STANDARDS
AND DEVELOPMENT UNIT**
Office 919-707-6950 FAX 919-250-4119

CURB RAMPS

ORIGINAL BY: J.S. HOWERTON DATE: 7/7/11
MODIFIED BY: DATE:
CHECKED BY: DATE:
FILE SPEC.: stds/2012CurbRamp/CurbRampDetails.dgn



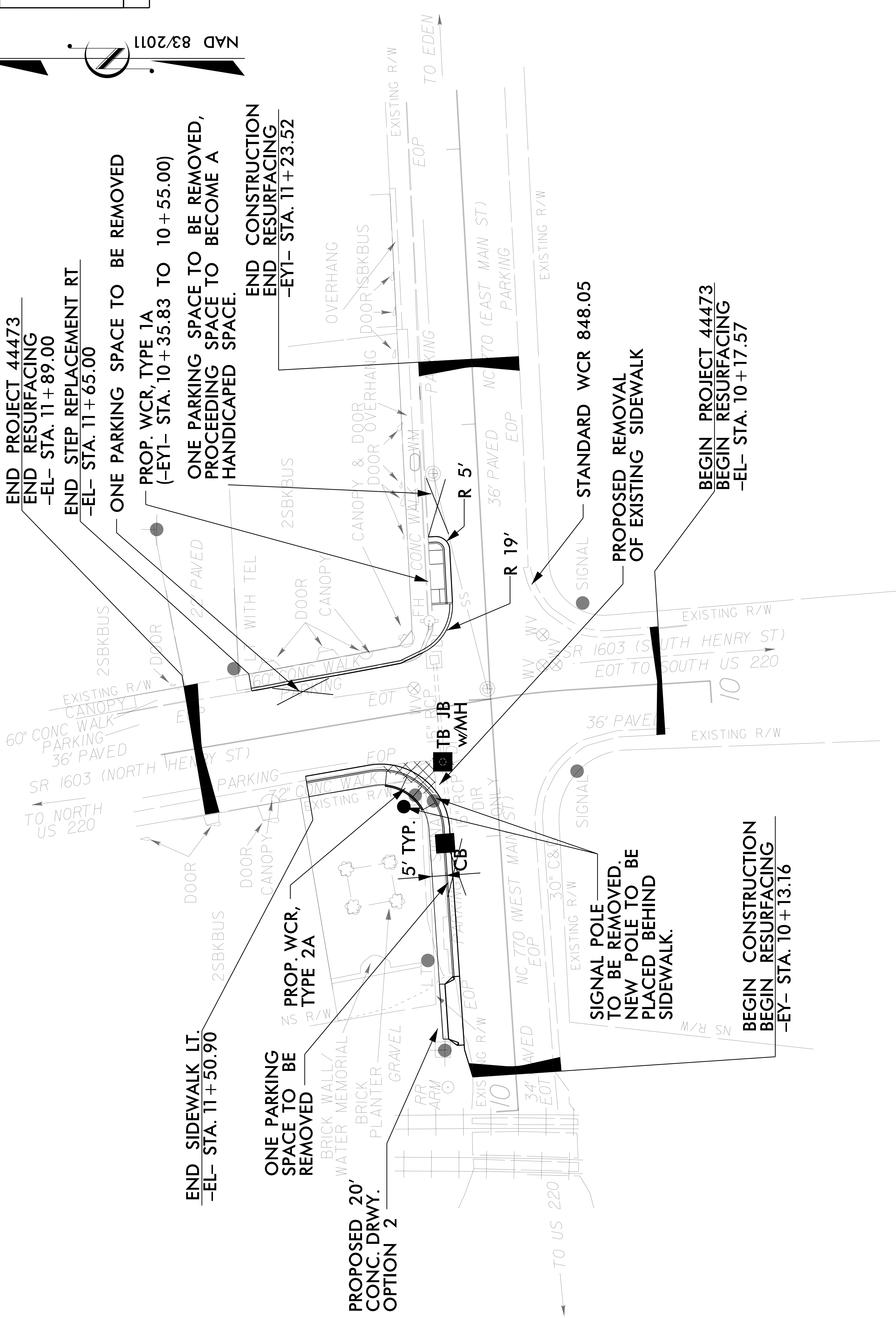
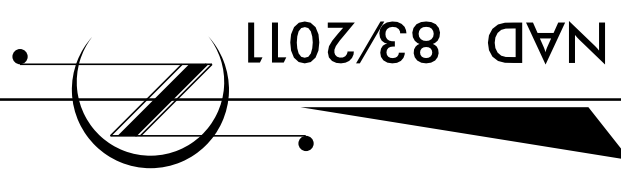
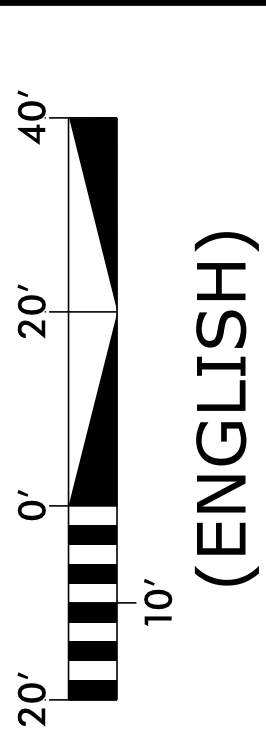

END PROJECT 44473
END RESURFACING
-EL- STA. 11+89.00
END STEP REPLACEMENT RT
-EL- STA. 11+65.00

ONE PARKING SPACE TO BE REMOVED
PROP. WCR, TYPE 1A
(-EY- STA. 10+35.83 TO 10+55.00)
ONE PARKING SPACE TO BE REMOVED,
PROCEEDING SPACE TO BECOME A
HANDICAPPED SPACE.

END CONSTRUCTION
END RESURFACING
-EY- STA. 11+23.52

STANDARD WCR 848.05

PROPOSED REMOVAL
OF EXISTING SIDEWALK

BEGIN PROJECT 44473
BEGIN RESURFACING
-EL- STA. 10+17.57

END SIDEWALK LT.
-EL- STA. 11+50.90

ONE PARKING
SPACE TO BE
REMOVED

PROP. WCR,
TYPE 2A

PROPOSED 20'
CONC. DRWY.
OPTION 2

SIGNAL POLE
TO BE REMOVED.
NEW POLE TO BE
PLACED BEHIND
SIDEWALK.

BEGIN CONSTRUCTION
BEGIN RESURFACING
-EY- STA. 10+13.16

REVISIONS



(ENGLISH)



END PROJECT 44473
END RESURFACING
-EL- STA. 11+89.00
END STEP REPLACEMENT RT
-EL- STA. 11+65.00

ONE PARKING SPACE TO BE REMOVED
PROP. WCR, TYPE 1A
(-EY1- STA. 10+35.83 TO 10+55.00)
ONE PARKING SPACE TO BE REMOVED,
PROCEEDING SPACE TO BECOME A
HANDICAPPED SPACE.

END CONSTRUCTION
END RESURFACING
-EY1- STA. 11+23.52

STANDARD WCR 848.05

PROPOSED REMOVAL
OF EXISTING SIDEWALK

BEGIN PROJECT 44473
BEGIN RESURFACING
-EL- STA. 10+17.57

END SIDEWALK LT.
-EL- STA. 11+50.90

ONE PARKING
SPACE TO BE
REMOVED

PROP. WCR
TYPE 2A

PROPOSED 20'
CONC. DRWY.
OPTION 2

SIGNAL POLE
TO BE REMOVED.
NEW POLE TO BE
PLACED BEHIND
SIDEWALK.

BEGIN CONSTRUCTION
BEGIN RESURFACING
-EY- STA. 10+13.16

REVISIONS

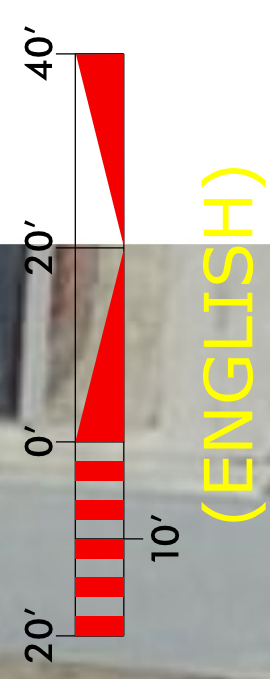

LEGEND & QUANTITIES

SYMBOL	DESCRIPTION	QUANTITY
TA	THERMOPLASTIC (4", 90 MILS) - WHITE EDGELINE TOTAL (4", 90 MILS)	152 LF 152 LF
TI	THERMOPLASTIC (4", 120 MILS) - YELLOW DOUBLE CENTER TOTAL (4", 120 MILS)	504 LF 504 LF
TO	THERMOPLASTIC (8", 90 MILS) - WHITE DIAGONAL TOTAL (8", 90 MILS)	33 LF 33 LF
T13	THERMOPLASTIC (8", 120 MILS) - WHITE CROSSWALK LINE TOTAL (8", 120 MILS)	326 LF 326 LF
T1	THERMOPLASTIC (16", 120 MILS) - WHITE LINE RR X TOTAL (16", 120 MILS)	22 LF 22 LF
T2	THERMOPLASTIC (24", 120 MILS) - WHITE STOPBAR TOTAL (24", 120 MILS)	80 LF 80 LF
UI	THERMOPLASTIC PAVEMENT MARKING CHARACTER (120 MILS) TOTAL PAVEMENT MARKING CHARACTERS (120 MILS)	2 EA 2 EA
UH	THERMOPLASTIC PAVEMENT MARKING SYMBOLS (90 MILS) TOTAL PAVEMENT MARKING SYMBOLS (90 MILS)	2 EA 2 EA
MA	PERMANENT RAISED PAVEMENT MARKERS TOTAL PERMANENT RAISED PAVEMENT MARKERS	7 EA 7 EA

TQ NOTE:
 STAMPED CROSSWALKS
 SEE STD. 1205.07 FOR
 WIDTHS AND NOTES

REVISIONS

Canine Carnival

Hosted by: Bark For Life of Rockingham County

When:

September 10th, 2016
11:00 AM until 3:00 PM

Where:

Stoneville Memorial Park
100 Priddy Dr
Stoneville, NC 27048

How Much:

Dog Participant fee of \$10

How do I register?

You can register by emailing Chrissy Griffin at chrissydgriffin@gmail.com or on our Facebook Page <https://www.facebook.com/bflrockinghamnc/>

We return for our 3rd Annual Bark For Life, and this year we are going to hold a Canine Carnival. We will have games, contests, prizes, vendors, demonstrations, and lots of fun. We will also take a moment to remember and recognize our four-legged caregivers and cancer survivors. We will have a Blessing of the Dogs for the dogs that are in attendance, and Rainbow Bridge to remember the dogs that we have lost.

The American Cancer Society Bark For Life is a fundraising event honoring the life-long contributions of our Canine Caregivers. It presents an opportunity for people to be empowered through their canine companion partnerships and to contribute to cancer cures through the mission of the American Cancer Society. Canine companions demonstrate unconditional love, joy, security, compassion, and no judgments of cancer survivors abilities or appearances.



**TOWN OF STONEVILLE
ASSET INVENTORY AND ASSESSMENT GRANT
RESOLUTION BY GOVERNING BODY OF APPLICANT**

WHEREAS, The Federal Clean Water Act Amendments of 1987 and the North Carolina the Water Infrastructure Act of 2005 (NCGS 159G) have authorized the making of loans and grants to aid eligible units of government in financing the cost of completing **Asset Inventory and Assessment (AIA) Grants**, and

WHEREAS, The **Town of Stoneville** has need for and intends to complete an **Asset Inventory and Assessment Program for the Town of Stoneville Sewer System** to include detailed system assessment and inventory documentation, capital planning, and related activities to assist in the future maintenance of the system and program, and

WHEREAS, The **Town of Stoneville** intends to request state grant assistance for the project,

NOW THEREFORE BE IT RESOLVED, BY THE TOWN COUNCIL OF THE TOWN OF STONEVILLE:

That the **Town of Stoneville**, the **Applicant**, will arrange financing for all remaining costs of the project, if approved for a State grant award.

That the **Applicant** will adopt and place into effect on or before completion of the project a schedule of fees and charges and other available funds which will provide adequate funds for proper operation, maintenance, and administration of the system and the repayment of all principal and interest for any system debt.

That the **Applicant** will provide for efficient operation and maintenance of the project components on completion thereof.

That **Ricky Craddock, Mayor and Kenneth Gamble, Town Manager**, the **Authorized Officials**, and successors so titled, are hereby authorized to execute and file an application on behalf of the **Applicant** with the State of North Carolina for a grant to aid in the completion of the project described above.

That the **Authorized Officials**, and successors so titled, are hereby authorized and directed to furnish such information as the appropriate State agency may request in connection with such application or the project: to make the assurances as contained above; and to execute such other documents as may be required in connection with the application.

That the **Applicant** has substantially complied or will substantially comply with all Federal, State, and local laws, rules, regulations, and ordinances applicable to the project and to Federal and State grants and loans pertaining thereto.

Adopted this the _____ day of _____, 2016, in Stoneville, North Carolina.

(Signature of Chief Executive Officer)

(Title)



CERTIFICATION BY RECORDING OFFICER

The undersigned duly qualified and acting Town Clerk of the Town of Stoneville does hereby certify:
That the above/attached resolution is a true and correct copy of the resolution authorizing the filing of
an application with the State of North Carolina, as regularly adopted at a legally convened meeting of
the Town of Stoneville Town Council duly held on the _____ day of _____, 2016; and,
further, that such resolution has been fully recorded in the journal of proceedings and records in my
office. IN WITNESS WHEREOF, I have hereunto set my hand this ____ day of _____, 2016.

(Signature of Recording Officer)

(Title of Recording Officer)



**TOWN OF STONEVILLE
ASSET INVENTORY AND ASSESSMENT GRANT
RESOLUTION BY GOVERNING BODY OF APPLICANT**

WHEREAS, The Federal Clean Water Act Amendments of 1987 and the North Carolina the Water Infrastructure Act of 2005 (NCGS 159G) have authorized the making of loans and grants to aid eligible units of government in financing the cost of completing **Asset Inventory and Assessment (AIA) Grants**, and

WHEREAS, The **Town of Stoneville** has need for and intends to complete an **Asset Inventory and Assessment Program for the Town of Stoneville Water System** to include detailed system assessment and inventory documentation, capital planning, and related activities to assist in the future maintenance of the system and program, and

WHEREAS, The **Town of Stoneville** intends to request state grant assistance for the project,

NOW THEREFORE BE IT RESOLVED, BY THE TOWN COUNCIL OF THE TOWN OF STONEVILLE:

That the **Town of Stoneville**, the **Applicant**, will arrange financing for all remaining costs of the project, if approved for a State grant award.

That the **Applicant** will adopt and place into effect on or before completion of the project a schedule of fees and charges and other available funds which will provide adequate funds for proper operation, maintenance, and administration of the system and the repayment of all principal and interest for any system debt.

That the **Applicant** will provide for efficient operation and maintenance of the project components on completion thereof.

That **Ricky Craddock, Mayor and Kenneth Gamble, Town Manager**, the **Authorized Officials**, and successors so titled, are hereby authorized to execute and file an application on behalf of the **Applicant** with the State of North Carolina for a grant to aid in the completion of the project described above.

That the **Authorized Officials**, and successors so titled, are hereby authorized and directed to furnish such information as the appropriate State agency may request in connection with such application or the project: to make the assurances as contained above; and to execute such other documents as may be required in connection with the application.

That the **Applicant** has substantially complied or will substantially comply with all Federal, State, and local laws, rules, regulations, and ordinances applicable to the project and to Federal and State grants and loans pertaining thereto.

Adopted this the _____ day of _____, 2016, in Stoneville, North Carolina.

(Signature of Chief Executive Officer)

(Title)



CERTIFICATION BY RECORDING OFFICER

The undersigned duly qualified and acting Town Clerk of the Town of Stoneville does hereby certify:
That the above/attached resolution is a true and correct copy of the resolution authorizing the filing of
an application with the State of North Carolina, as regularly adopted at a legally convened meeting of
the Town of Stoneville Town Council duly held on the _____ day of _____, 2016; and,
further, that such resolution has been fully recorded in the journal of proceedings and records in my
office. IN WITNESS WHEREOF, I have hereunto set my hand this ____ day of _____, 2016.

(Signature of Recording Officer)

(Title of Recording Officer)



Proclamation for National Police Week 2016

To recognize National Police Week 2016 and to honor the service and sacrifice of those law enforcement officers killed in the line of duty while protecting our communities and safeguarding our democracy.

WHEREAS, there are approximately 900,000 law enforcement officers serving in communities across the United States, including the dedicated members of the **Town of Stoneville Police Department**;

WHEREAS, there have been 15,725 assaults against law enforcement officers in 2014, resulting in approximately 13,824 injuries;

WHEREAS, since the first recorded death in 1791, more than 20,000 law enforcement officers in the United States have made the ultimate sacrifice and been killed in the line of duty;

WHEREAS, the names of these dedicated public servants are engraved on the walls of the National Law Enforcement Officers Memorial in Washington, D.C.;

WHEREAS, 252 new names of fallen heroes are being added to the National Law Enforcement Officers Memorial this spring, including 123 officers killed in 2015 and 129 officers killed in previous years;

WHEREAS, the service and sacrifice of all officers killed in the line of duty will be honored during the National Law Enforcement Officers Memorial Fund's 28th Annual Candlelight Vigil, on the evening of May 13, 2016;

WHEREAS, the Candlelight Vigil is part of National Police Week, which takes place this year on May 15-21;

WHEREAS, May 15 is designated as Peace Officers Memorial Day, in honor of all fallen officers and their families and U.S. flags should be flown at half-staff;

THEREFORE, BE IT RESOLVED that **The Stoneville Town Council** formally designates May 15-21, 2016, as Police Week in **Stoneville North Carolina**, and publicly salutes the service of law enforcement officers in our community and in communities across the nation.

Ricky Craddock, Mayor

Sherri Darnell, Town Clerk



Proclamation

Public Works Week 2016

WHEREAS, public works infrastructure, facilities and services are of vital importance to sustainable communities and to the health, safety and well-being of the people of **The Town of Stoneville**; and

WHEREAS, public works facilities and services could not be provided without the dedicated efforts of the public works professionals, engineers, managers and employees from State and local Government and the private sector who plan, design, build, operate, and maintain the transportation, water supply, water treatment and solid waste systems, public buildings, and other structures and facilities essential to serve our citizens; and

WHEREAS, it is in the public interest for residents to understand the importance of public works and public works programs in their respective communities; and

WHEREAS, 2016 marks the 56th annual National Public Works Week sponsored by the American Public Works Association;

NOW, THEREFORE, I, **Ricky Craddock, Mayor of the Town of Stoneville**, do hereby proclaim **May 15-21, 2016** as **NATIONAL PUBLIC WORKS WEEK**.

And I encourage all residents to recognize the contributions of our public works professionals, engineers, managers and employees.

Dated this 10th day of May, 2016.

Ricky Craddock, Mayor

Sherri Darnell, Town Clerk

Town Council Meeting

May 10, 2016



SAFETY SURVEY



GENERAL SENSE OF SECURITY AT WORK

- Safe from all forms of violence.
 - Civilian – 15%
 - LEO – 33%
- Rarely feel uncomfortable during interactions.
 - Civilian – 54%
 - LEO – 33%

GENERAL SENSE OF SECURITY AT WORK

- Sometimes feel threatened
 - Civilian – 23%
 - LEO – 33%

THREATENED WITH PHYSICAL VIOLENCE OR ASSUALTED IN LAST 2 YEARS

- Yes

- Civilian – 0%
- LEO – 17%

- No

- Civilian – 100%
- LEO – 83%

CAN THE TOWN IMPROVE EMPLOYEE SENSE OF SECURITY AT WORK?

- Yes

- Civilian – 69%
- LEO – 50%

- No

- Civilian – 31%
- LEO – 50%

MOST / LEAST EFFECTIVE ACTIONS

- Requiring officer on duty to patrol town buildings during work day. (Civilian)
 - Most Effective – 54%
 - Least Effective – 8%
- Requiring officer on duty to patrol town buildings during work day. (LEO).
 - Most Effective – 33%
 - Least Effective – 0%

MOST/ LEAST EFFECTIVE ACTIONS

- Installing metal detectors in Town buildings. (Civilian)
 - Most Effective – 23%
 - Least Effective – 23%
- Installing metal detectors in Town buildings (LEO).
 - Most Effective – 33%
 - Least Effective – 17%

MOST / LEAST EFFECTIVE ACTIONS

- Self defense class. (Civilian)
 - Most Effective – 8%
 - Least Effective – 15%
- Self defense class. (LEO)
 - Most Effective – 17%
 - Least Effective – 17%

MOST / LEAST EFFECTIVE ACTIONS

- Posting a sign prohibiting concealed firearms. (Civilian)
 - Most Effective – 8%
 - Least Effective – 62%
- Posting a sign prohibiting concealed firearms (LEO).
 - Most Effective – 33%
 - Least Effective – 50%

WOULD ALLOWING OPEN AND/OR CONCEALED CARRY OF FIREARMS ON TOWN OWNED PROPERTY MAKE YOU SAFER AT WORK?

- Civilian

- Yes – 46%
- No – 8%
- Unsure – 46%

- LEO

- Yes – 50%
- No – 33%
- Unsure – 17%

SHOULD TOWN EMPLOYEES WITH A CCW PERMIT BE ALLOWED TO CARRY ON TOWN OWNED PROPERTIES?

- Civilian

- Yes – 100%
- No – 0%

- LEO

- Yes – 100%
- No – 0%

SHOULD TOWN COUNCIL MEMBERS WITH A CCW PERMIT BE ALLOWED TO CARRY ON TOWN OWNED PROPERTIES?

- Civilian

- Yes – 100%
- No – 0%

- LEO

- Yes – 100%
- No – 0%

SHOULD MEMBERS OF THE PUBLIC WITH A CCW PERMIT BE ALLOWED TO CARRY ON TOWN OWNED PROPERTIES?

- Civilian

- Yes – 69%
- No – 23%
- Nonresponse – 8%

- LEO

- Yes – 83%
- No – 17%

SHOULD ONLY SWORN LAW ENFORCEMENT OFFICERS BE ALLOWED TO CARRY ON TOWN OWNED PROPERTIES?

- Civilian

- Yes – 8%
- No – 92%

- LEO

- Yes – 17%
- No – 83%